

Installation and operating instruction
Symondo Controller



Read carefully before installation, commissioning and operation

CONTENT

Safety Instructions	3
EG-Conformity	3
General Instructions	3
Changes to the Unit	3
Warranty and Liability	4
Disposal and Pollutants	4
Description Symondo Controller	5
Technical Data	5
Scope of Supply	5
Installation	6
Symondo Controller installation	6
Example Controller-Connection	8
Example CAN-Connection	8
Operation	9
Room Overview	9
Operating Mode	10
Menu	10
Set Operation Hours	11
Set Operation Hours	12
Expert Menu	13
Settings	13
Devices	14
Rooms	15
Sensors	16
Functions	17
Service Values	21
Support	22
Notes	22

SAFETY INSTRUCTIONS

EG-Conformity

By affixing the CE mark to the unit the manufacturer declares that Symondo Controller conforms to the following relevant safety regulations:

- EU low voltage directive 2014/35/EU
- EU electromagnetic compatibility directive 2014/30/EU

conforms. Conformity has been verified and the corresponding documentation and the EU declaration of conformity are kept on file by the manufacturer.

General Instructions

Please read carefully!

These installation and operating instructions contain basic instructions and important information regarding safety, installation, commissioning, maintenance and the optimal use of the unit. Therefore these instructions must be read and understood completely by the installation

technician/specialist and by the system user before installation, commissioning and operation of the unit.

This unit is an automatic, electrical Symondo Controller. Install the unit only in dry areas and under the ambient conditions described in "Specifications".

In addition, observe the applicable accident prevention regulations, the regulations of the Association of Electrical Engineering, the local power supply utility, the applicable DIN-EN standards and the installation and operating instructions for the additional system components. Installation, electrical connection, commissioning and maintenance of the device may only be carried out by an appropriately trained specialist.

Users: Make sure that the specialist gives you detailed information on the function and operation of the unit. Always keep these instructions in the vicinity of the unit.

The manufacturer does not take over any liability for damage caused through improper usage or non-compliance of this manual!



Before working on the unit, switch off the power supply and secure it against being switched on again! Check that there is no power flowing! Electrical connections may only be made by a specialist and in compliance with the applicable regulations. The unit may not be put into operation if there is visible damage to the housing, e.g. cracks.

Changes to the Unit

- Changes, additions to or conversion of the unit are not permitted without written permission from the manufacturer.
- It is likewise forbidden to install additional components that have not been tested together with the unit.
- If it becomes clear that safe operation of the unit is no longer possible, for example because of damage to the housing, turn the Unit off immediately.
- Any parts of the unit or accessories that are not in perfect condition must be exchanged immediately.
- Use only original spare parts and accessories from the manufacturer.
- Markings made on the unit at the factory must not be altered, removed or made illegible.
- Only the settings described in these instructions may be set using the Unit.



Changes to the unit can compromise the safety and function of the unit or the entire system.

Warranty and Liability

The Unit has been manufactured and tested with regard to high quality and safety requirements. The warranty and liability shall not include, however, any injury to persons or material damage that is attributable to one or more of the following causes:

- Failure to observe these installation and operating instructions.
- Improper installation, commissioning, maintenance and operation.
- Improperly executed repairs.
- Unauthorised structural changes to the unit.
- Use of the device for other than its intended purpose.
- Operation above or below the limit values listed in the 'Specifications' section.
- Force majeure.

Disposal and Pollutants

The unit conforms to the European RoHS 2011/65/EU for the restriction of the use of certain hazardous substances in electrical and electronic equipment.





Under no circumstances may the device be disposed of with the normal household waste. Dispose of the unit only at appropriate collection points or ship it back to the seller or manufacturer.

DESCRIPTION SYMONDO CONTROLLER

Technical Data



	Housing	2-part, ABS plastic 75 mm x 95 mm x 19 mm Glass front
	Display	Capacitive touch panel Color display with 240x320 dots 2.8 inches (7 cm) diagonal
	Operation	Intuitive user guidance
	Language	Deutsch Italiano English Français Español Português

Electrical specifications:

Power Supply	12 - 24 VDC +/- 10%
power consumption	max. 2,5 W
Protection Class	IP20
Protection class / overvoltage category	0/III

Max. Cable Length

0-10V/PWM	<3m, if the cable length is >=3m it is necessary to use a shielded twisted pair bus cable and connect the shield on one side to the protective conductor.
1-Wire Bus	Optional, without function

Permissible Ambient Conditions

during operation	0 °C - 50 °C, no moisture condensation permitted
for transport/storage	0 °C - 60 °C, no moisture condensation permitted

Measurement Range

Outside the measuring ranges there are larger deviations	
Internal temperature sensor	0 °C - 60 °C Accuracy +/- 1 °C Resolution 0,1 °C
Internal sensor for rel. humidity	0 % - 100 % Accuracy +/- 6 °C Resolution 0,1 %
1-Wire temperature sensors	Optional, without function

 After switching on or disconnecting from the mains, it takes up to 60 minutes until the temperature is displayed precisely.

Other Specifications

Installation Methods	Wall installation, with/without wall socket
Real Time Clock	RTC with 24 hour power reserve

Scope of Supply

- Symondo Controller
- 2 screws 3,5 x 35 mm and 2 plugs 6 mm for wall installation.
- Symondo Controller installation guide

INSTALLATION

Symondo Controller installation

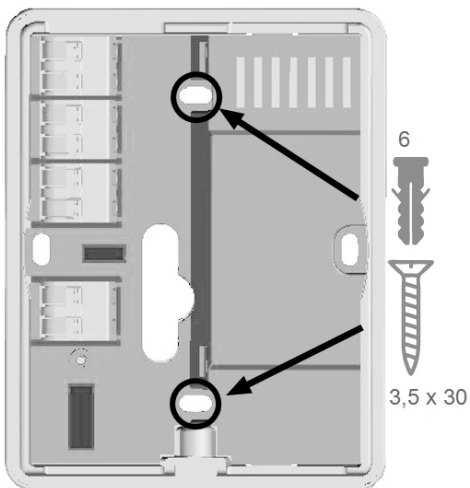
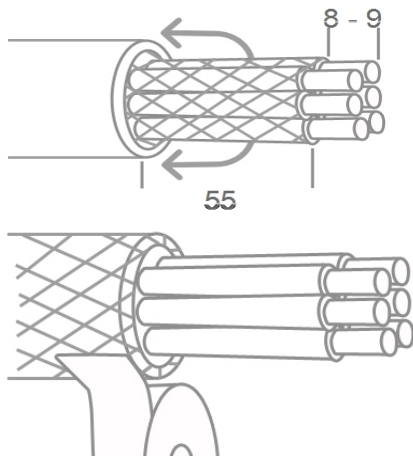
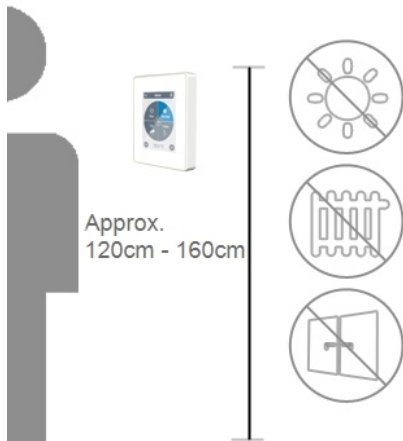

Mount the unit at a suitable location.



Pay attention to suitable environmental conditions. Direct sunlight, sources of heat and cold, e.g. radiators and windows must be avoided.

When wall mounting, make sure that the cables are kept as short as possible (max. 40 mm for direct wall mounting), as unnecessary vein loops in the Symondo Controller housing can lead to problems.

When mounting on a switch box, make sure that the cables are kept as short as possible (strip cables max. 55 mm) and that any vein loops are fed back into the switch box, as unnecessary vein loops in the Symondo Controller housing can lead to problems.

Strip the last 8 - 9 mm of the wires. Isolate shielding and connect it at a suitable location (controller or CAN-box) to the protective conductor.



Any contact between protective conductor and circuit board can cause serious damage.

Mounting on plastic wall socket

Fix the base with the screws (3,0 x 16) to the mounting box.

Direct wall mounting

Hold the lower part of the housing up to the selected position and mark the three mounting holes. Make sure that the wall surface is as even as possible so that the housing does not become distorted when it is screwed on. Using a drill and drill holes at the points marked on the wall and push in the plugs. Insert screws and screw it in slightly. Align the base and tighten the screws.

Open the terminals with the accompanying operating tool and make the electrical connection as described.



Power supply 24 VDC, ensure correct polarity or it may cause damage to the unit!

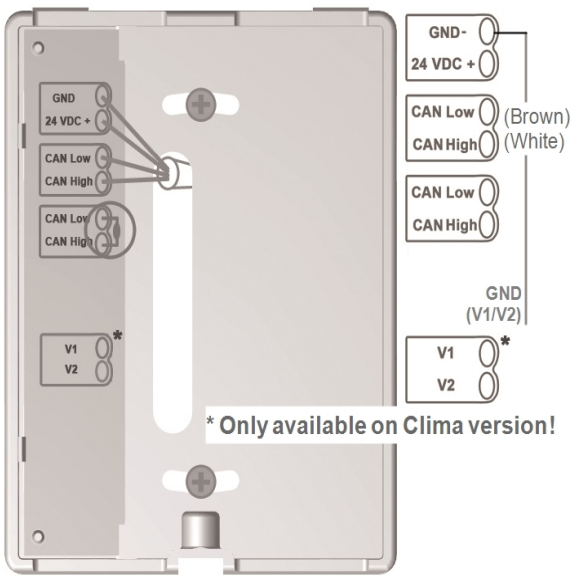

 The first and last unit in the CAN-network in series must be fitted with terminating resistance.



The connection of the opposite side (controller) can be found in the corresponding terminal diagram in the controller manual.

Refit the base and fasten with screw. Switch on the mains voltage and put Symondo Controller into operation.

 The setup wizard can be called up at any time in the Symondo Controller menu under Expert.

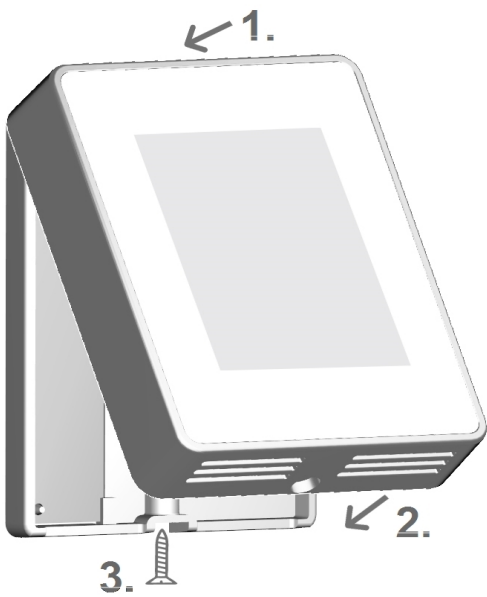

Example Controller-Connection

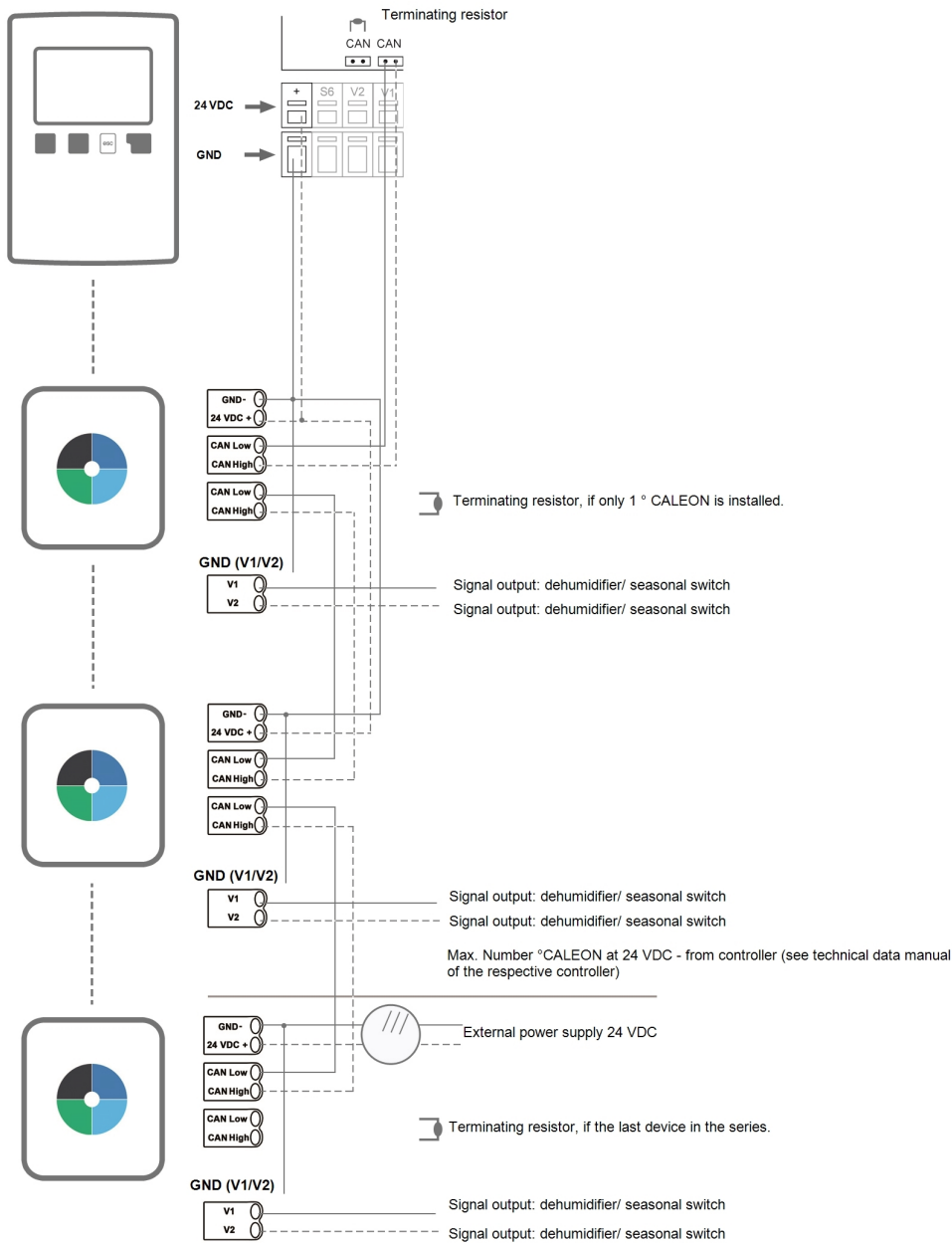

Example CAN-Connection

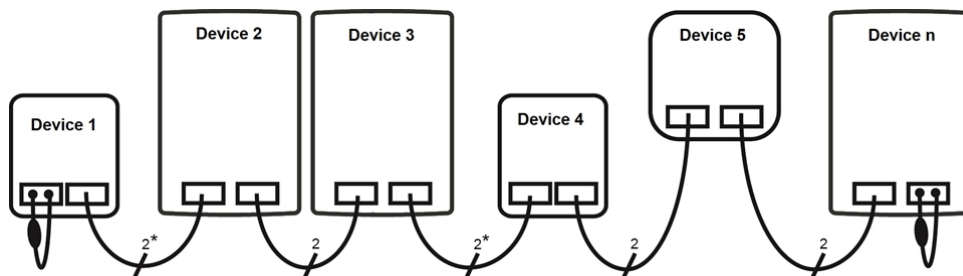

*Only CAN in power supply from 4 cores of the regulator.

The order and the number of devices (max. 50) is arbitrary.

Room Overview

Displays the room temperature, humidity and external temperature once the start screen was activated.



Room icon

Selecting a room icon takes you to the room temperature settings.

Multiroom selection

By dragging your finger vertically across several rooms, you can change the operating mode in all rooms at the same time.

outdoor temperature

Displayed as soon as an outdoor sensor is used on the HCC or an outdoor sensor is activated on a Symondo Box in the menu "Expert > Symondo Box > Heating circuit > Sensor outdoor".

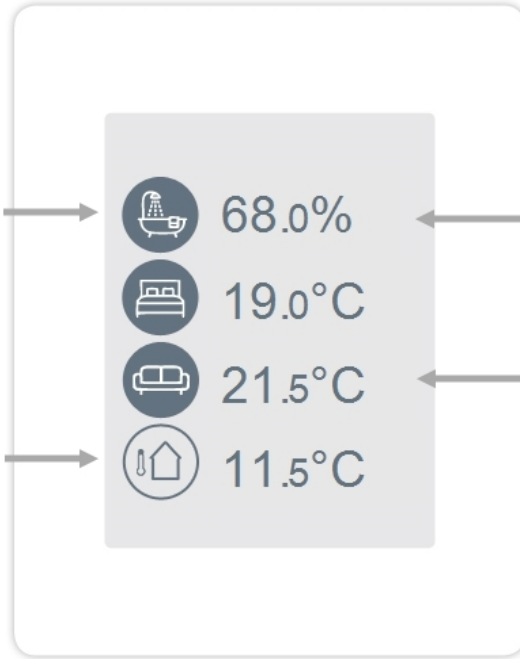

%

Room humidity

Relative humidity.

°C

Room temperature

Current room temperature.

Operating Mode

Overview > Operating Mode



Back/ Forward

Navigate back to the overview.



Room

Displays the selected space.



Reference temperature

Setting the reference temperature for the active operating mode in the displayed room.

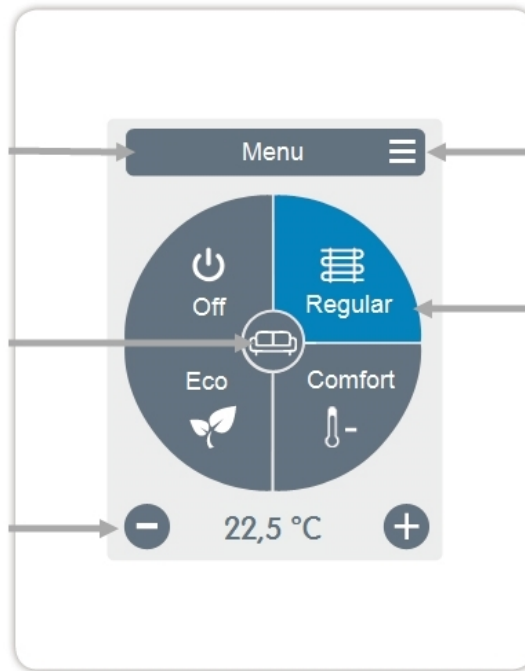

Menu

Navigate to the main menu



Operating Modes

The operating mode shown in colour is currently active and can be changed by selecting another mode. Manually selected modes remain active until the next change of mode by the timer program. A background frost protection function remains active in the "off" mode.

Menu

Overview > Operating Mode > Menu



Heating/cooling

Switch between heating and cooling modes.



Holiday

Set the period and temperature for a longer absence.

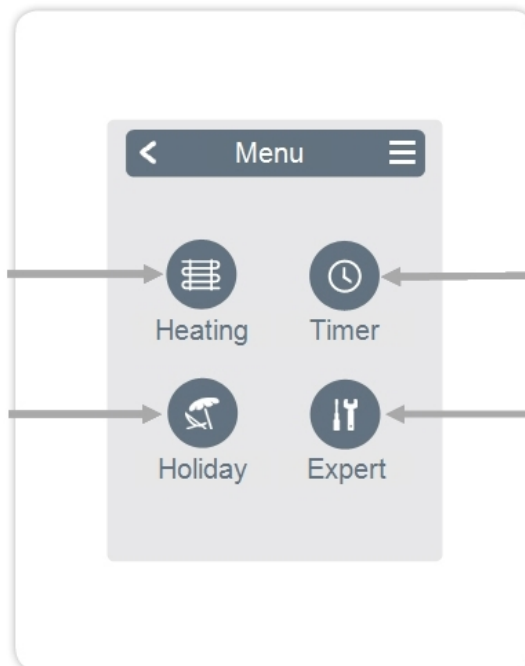

Timer

Setting of individual heating or cooling times for each day of the week with copy function for subsequent days.



Expert

Advanced settings for the technician.

Set Operation Hours

Overview > Operating Mode > Menu > Timer

Setting of individual heating and cooling times for the selected room.

Separate times are set for the heating and cooling modes. To do this, first switch to the heating mode and define the corresponding times for this operating mode under Main menu > Timer. Then change to the cooling mode and define the corresponding times for this operating mode under Main menu > Timer.



Operating Modes

Selection of the operating mode to select individual heating or cooling sections.

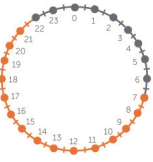

Clock

Time table of the selection in periods of 30 minutes increments. Touch individual segments, or drag your finger over complete time intervals to colour them according to the selected operation mode.

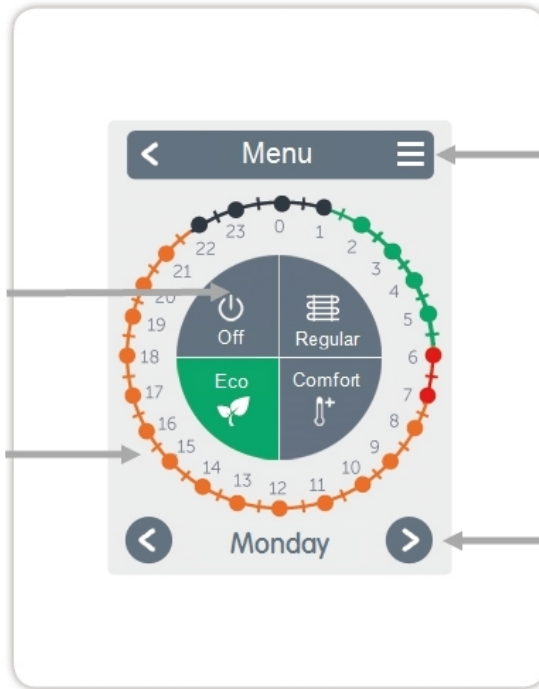

Menu

Opens the copy function. The function allows you to copy the heating and cooling times to the following day, to Monday - Friday or to Monday - Sunday.



Monday



Back / Next Weekday

Selects the set day.

Set Operation Hours

Step 1

Use the arrow keys to select the desired day.

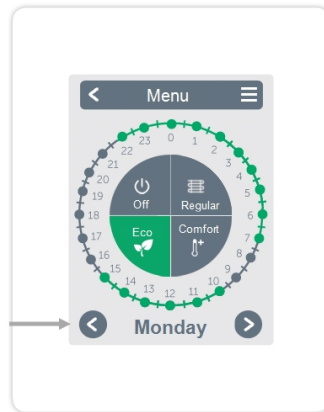

Step 2

Select the first heating mode (Normal) - with the index finger select the desired length of time. The selected period will be coloured after selecting the colour of the operating mode (normal = orange). Set the times of the other operating modes in the same way.

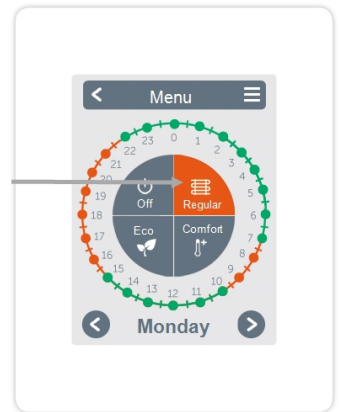

Step 3

After completing the setting of the individual heating or cooling times, you have the option of copying the times via the main menu to the following day, to Monday - Friday or to Monday - Sunday or to set them individually for each day of the week.

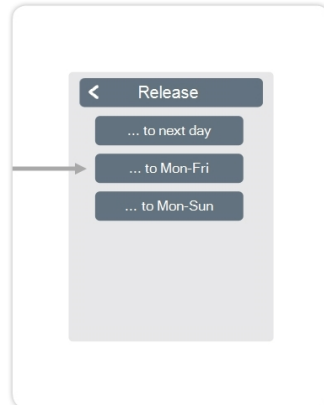

In the interests of efficient and energy-saving single room control, the operating times should be set specifically for each room.

Expert Menu

Overview > Operating Mode > Menu > Expert

Select Language

Set the device language.

Settings

Parameterisation of heating/cooling system.

Menu Lock

Activate menu lock to protect settings with a password.

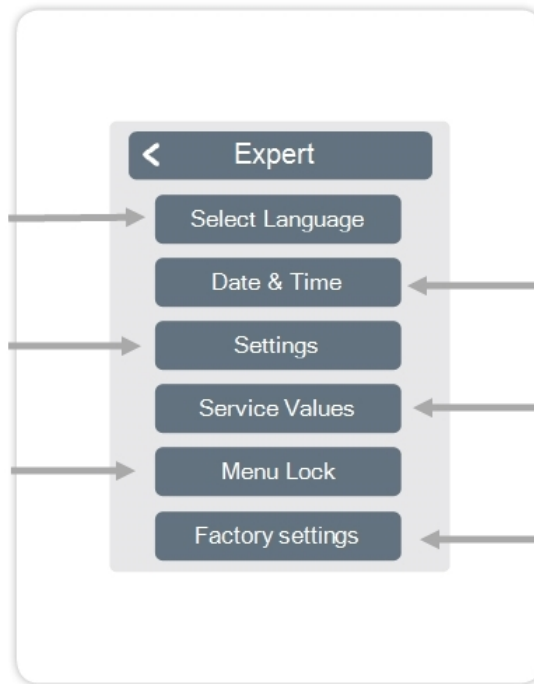

Date & Time

Setting of time and date and automatic summer/winter time changeover.

Service Values

Information about the system.

Factory settings

The factory settings are restored in the device.

 The menu structure described here is based on the status at the time of production and may vary due to subsequent software changes.

Settings

Overview > Operating Mode > Menu > Expert > Settings

Devices

Add, manage and remove connected devices.

Symondo Controller

Assignment and configuration of additional functions for free switching outputs.

Interface Mode

Switch between full and restricted menu. Only the reference temperature can be set in the mode "Hide menu". To return to "full" mode, press and hold the upper-right corner of the display for 5 seconds.

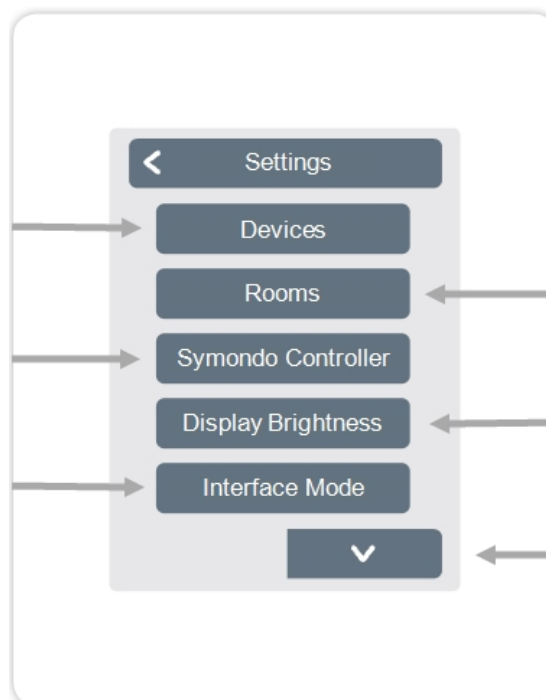

Rooms

Add, manage and remove rooms and assign them to connected devices.

Display Brightness

Adjust the screen brightness.

Room Sync.

If room synchronisation is activated, rooms set up on other Symondo Controller of the same network are also displayed on this Symondo Controller and vice versa.

Devices



Clima systems have to be switched to 'heating' mode before another device can be added to a running system.



Add Device

Starts the search for new available devices in the network.



Device icon

Shows the type of connected device and its CAN ID.

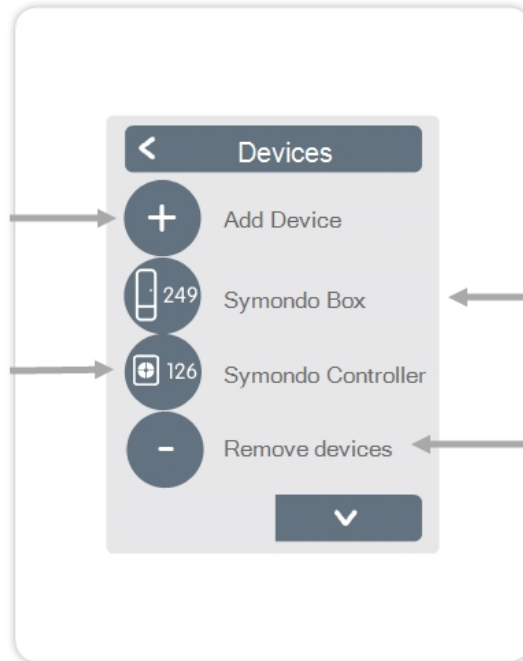

Description

Displays the detected type of the device.



Remove devices

Devices are removed from the network.

Rooms

Overview > Operating mode > Menu > Expert > Settings > Rooms



Add Room
Adding rooms.



Room 2
Setting the location, sensors and actuators of the respective room.

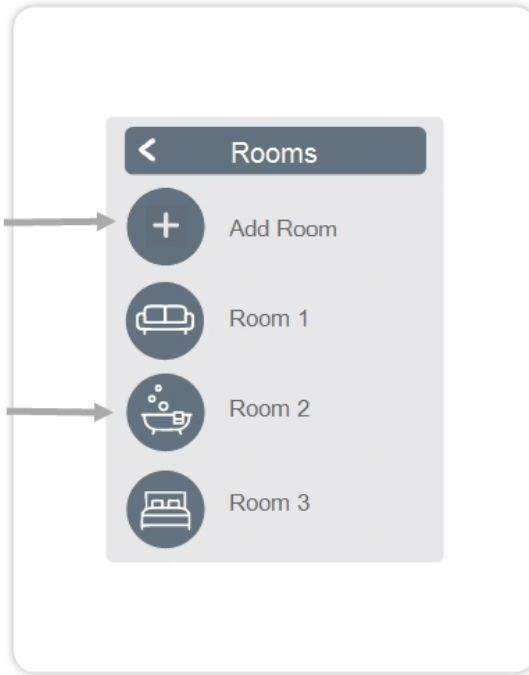

Overview > Operating mode > Menu > Expert > Settings > Room 2

Location
Selection of room icon.

Modulation Humidity
Sensors in the selected room.

Remove Room
Remove the selected room.

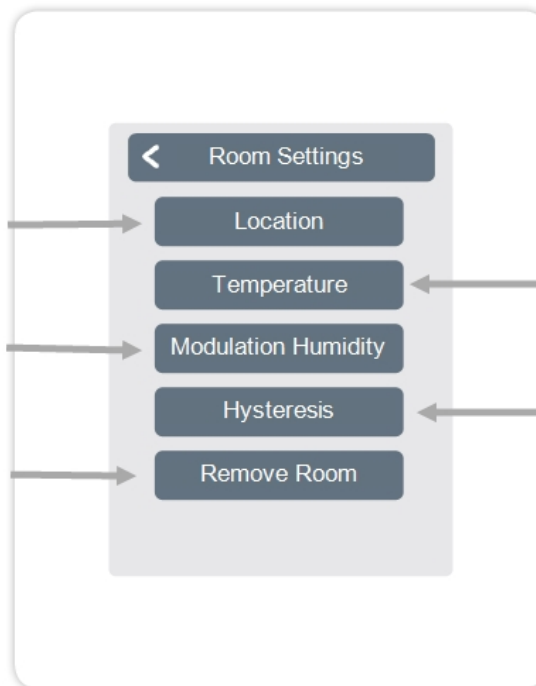

Temperature
Sensors in the selected room.

Hysteresis
Switch-off hysteresis for the room set-point temperature.

Sensors

Overview > Operating mode > Menu > Expert > Settings > Rooms > Room 1 > Sensors > Temperature



Icon
Sensor already selected.

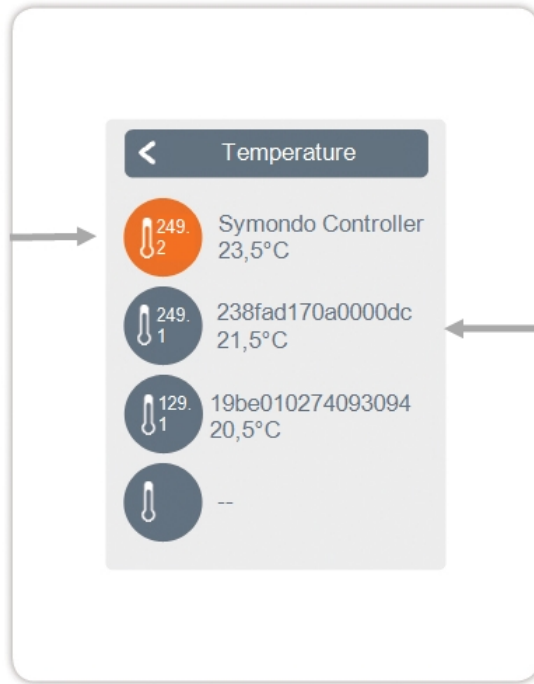

Sensoricon with CAN ID + number
Temperature sensor selection in the selected room.

Overview > Operating mode > Menu > Expert > Settings > Rooms > Room 1 > Sensors > Humidity



Sensoricon with CAN ID + number
Humidity sensor selection in the selected room.

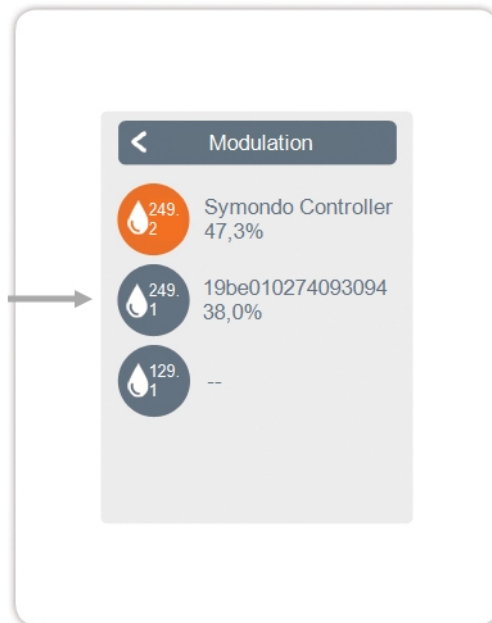

Functions

Overview > Operating mode > Menu > Expert > Settings > Functions

Activate and set additional functions.

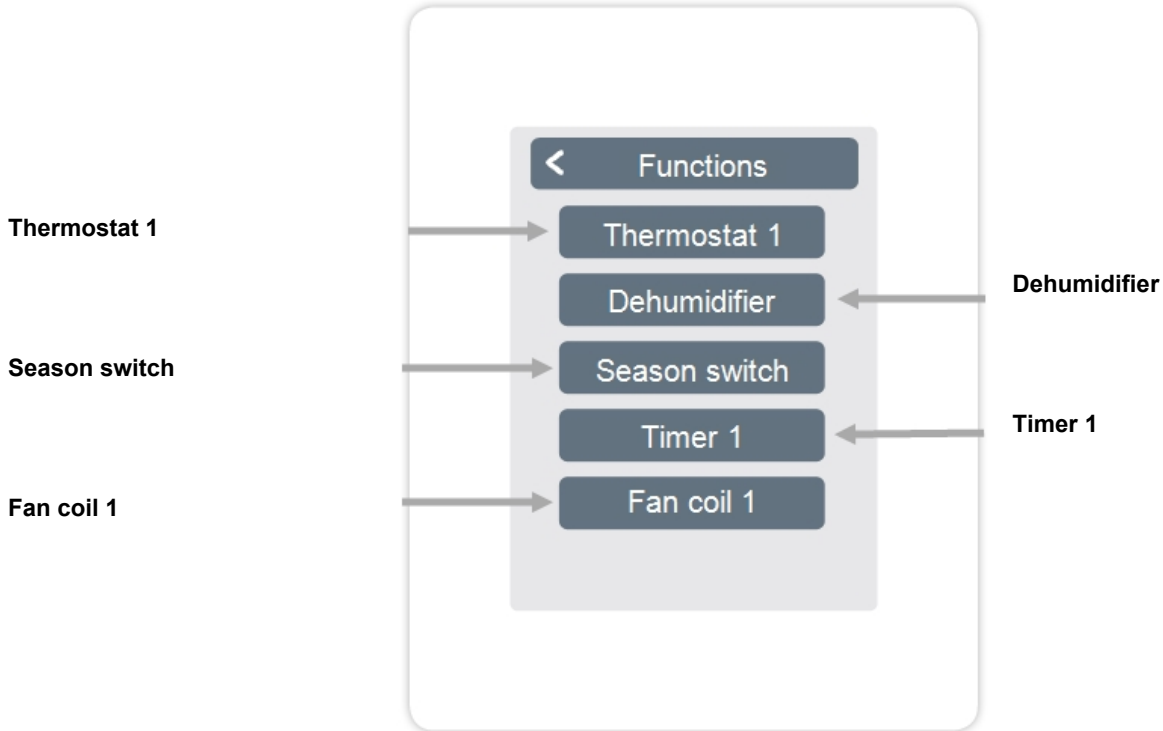

Overview > Operating mode > Menu > Expert > Settings > Functions > Thermostat 1

Switches the defined output to the set room / rooms depending on time and temperature.

Output

Assign the output to be switched by the function. The other menu options become visible after assigning the output.

Operating Mode

Set the operating mode of this thermostat function. Heating, cooling, or heating and cooling.

Seizing Protection

If the seizing protection is activated (daily, weekly, off), the controller switches on the outputs one after the other at 12:00 noon for 5 seconds to prevent seizing of the connected device during longer inactivity.

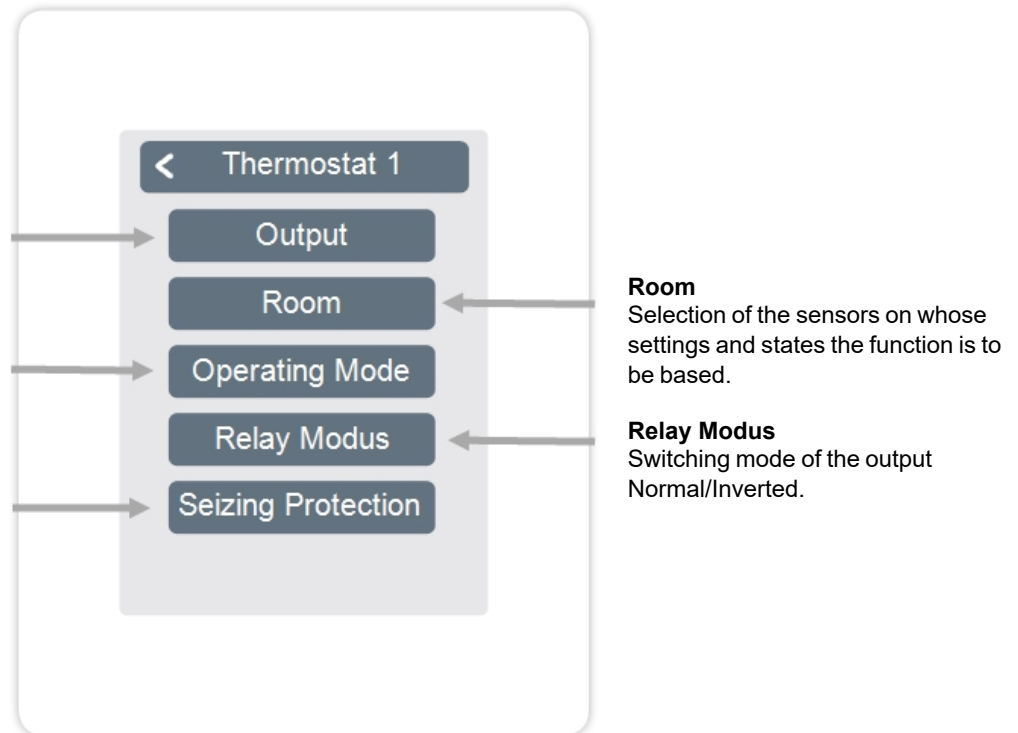

The dehumidifier function switches the defined output depending on the set humidity in the set room(s).

Output

Assign the output to be switched by the function. The other menu options become visible after assigning the output.

Modulation Humidity

Set the limit value for the air humidity. If this is exceeded, the dehumidifier is switched on.

Room

Room selection for assigning the humidity of a room as the basis for switching the dehumidifier.

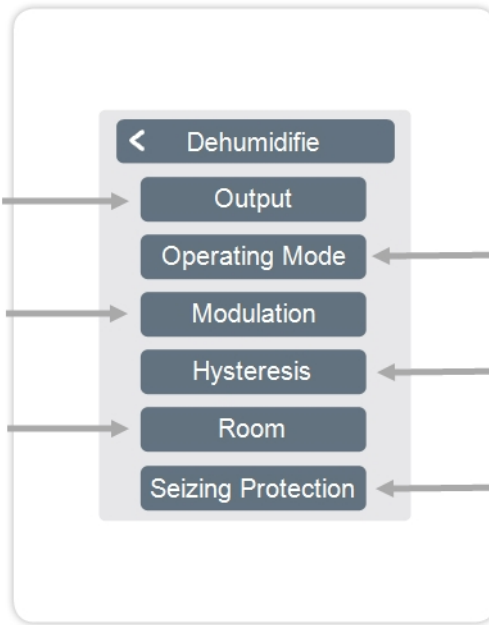

Operating Mode

Specify in which operating states of the heating and cooling system the dehumidifier is to be switched on.

Hysteresis

Define the switch-off hysteresis.

Seizing Protection

If the seizing protection is activated (daily, weekly, off), the controller switches on the outputs one after the other at 12:00 noon for 5 seconds to prevent seizing of the connected device during longer inactivity.

The seasonal switch changes the operating mode of the heat pump (compressor) between "heating" and "cooling". Therefore the heat pump (compressor) must be compatible with reversible operation.

Output

Assign the output to be switched by the function. The other menu options become visible after assigning the output.

Seizing Protection

If the seizing protection is activated (daily, weekly, off), the controller switches on the outputs one after the other at 12:00 noon for 5 seconds to prevent seizing of the connected device during longer inactivity.

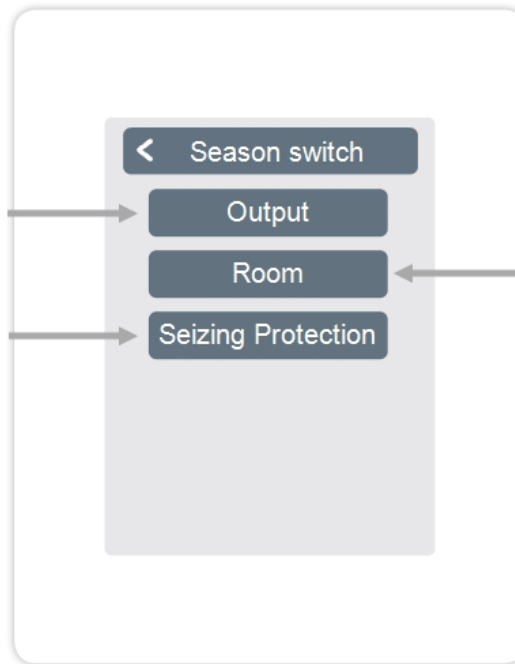

Room

Room selection to start the function. As soon as one of the assigned rooms switches from "heating" mode to "cooling" mode the season switch becomes active and the assigned relay is switched.

The function Timer 1-2 switches the defined output depending on the set times.

Output

Assign the output to be switched by the function.

The other menu items become visible after the output has been assigned, as soon as at least one created room has a heat demand.

Seizing Protection

If the seizing protection is activated (daily, weekly, off), the controller switches on the outputs one after the other at 12:00 noon for 5 seconds to prevent seizing of the connected device during longer inactivity.

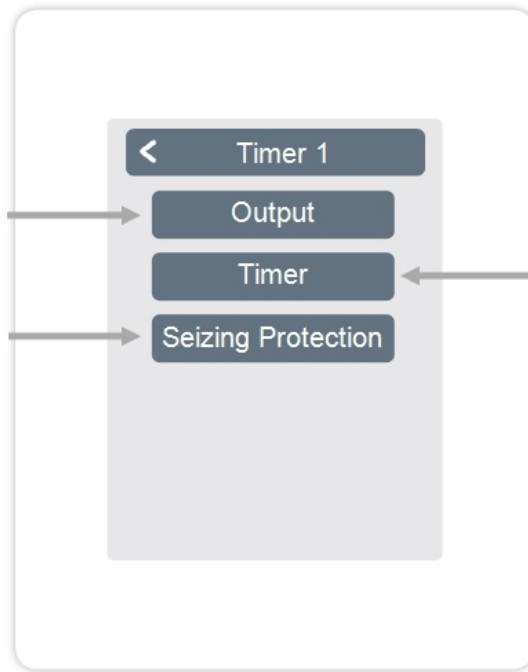

Timer

Set the times at which the outputs are to be switched.

The fan coil function controls convection heating and cooling via the 0-10V/PWM outputs .

Output

Assign the output to be switched by the function.

The other menu options become visible after assigning the output.

Flow

Assignment of the convector flow sensor in "Heating" mode.

Room

Selection of the sensors on whose settings and states the function is to be based.

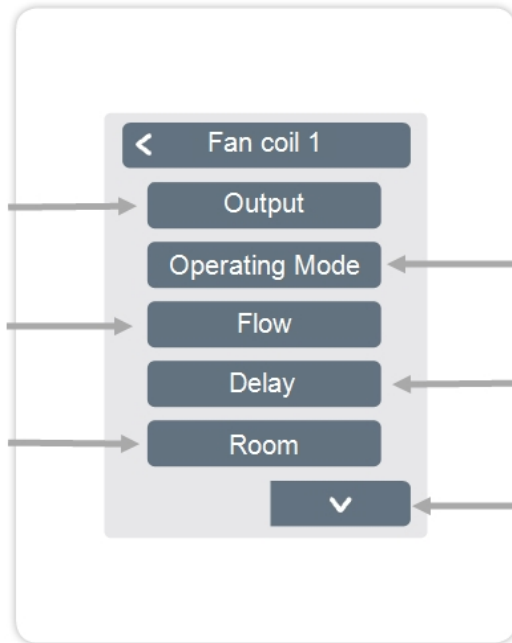

Operating Mode

Set the operating mode of this convector function. Heating, cooling, or heating and cooling.

Delay

Delays the switching on of the fan coil so that it does not push against closed valves.

Modulation Humidity

Set the limit value for the air humidity. If this is exceeded, the dehumidifier is switched on.

Hysteresis

Define the switch-off hysteresis.

Modulation

Modulation of the output for power control

Signal type

Selection of the control:
 0-10V = voltage signal
 PWM = square wave signal

Relay Modus

Switching mode of the output
 Normal/Inverted.

Off Signal

Signal to switch off the target device

On Signal

Signal to switch on the target device at minimum power

Max Signal

Signal to set target device to maximum power

Seizing Protection

If the seizing protection is activated (daily, weekly, off), the controller switches on the outputs one after the other at 12:00 noon for 5 seconds to prevent seizing of the connected device during longer inactivity.

Message Log
Displays the error memory.

System Status
Enables an update of all connected components.

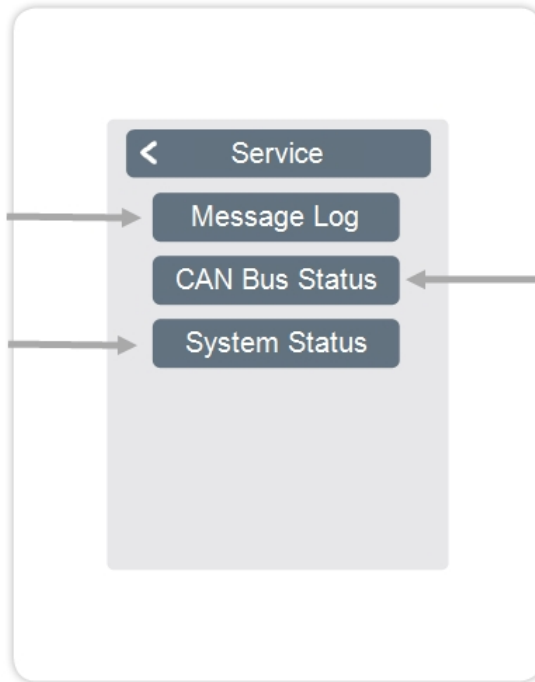

CAN Bus Status
Display the CAN bus status.

Support

Event	Support
The display does not show anything.	Is the device connected to the power supply? Is the mains connection voltage? Has the electrical connection been made as described in the user manual?
The heating/cooling circuit does not respond to my Symondo Controller.	Is Symondo Controller assigned to the heating circuit in the controller menu? Is the CAN bus wiring between controller and Symondo Controller correct?
The CAN bus connection is incorrect.	Is the CAN bus connection properly installed and have all devices been wired <u>in line</u> (no star!)? Are end resistors set on the first and last device for termination of the bus?
No additional function can be assigned to a relay/V output under "Functions".	Is the selected function already assigned to another output? Is the output already assigned to another function?

Notes

Final Declaration

Although these instructions have been created with the greatest possible care, the possibility of incorrect or incomplete information cannot be excluded. Subject as a basic principle to errors and technical changes.

Date and time of installation:

Name of installation company:

Space for notes:

MULTIBETON Produktions- und Vertriebsgesellschaft
für Heizungs- und Energietechnik mbH

Heuserweg 23
53842 Troisdorf-Spich

Telefon: +49 22 41 25200-0
Telefax: +49 22 41 25200-99

info@multibeton.de
www.multibeton.de

Version: 20.04.2023